

Flat Pattern view
SCALE: 2:1

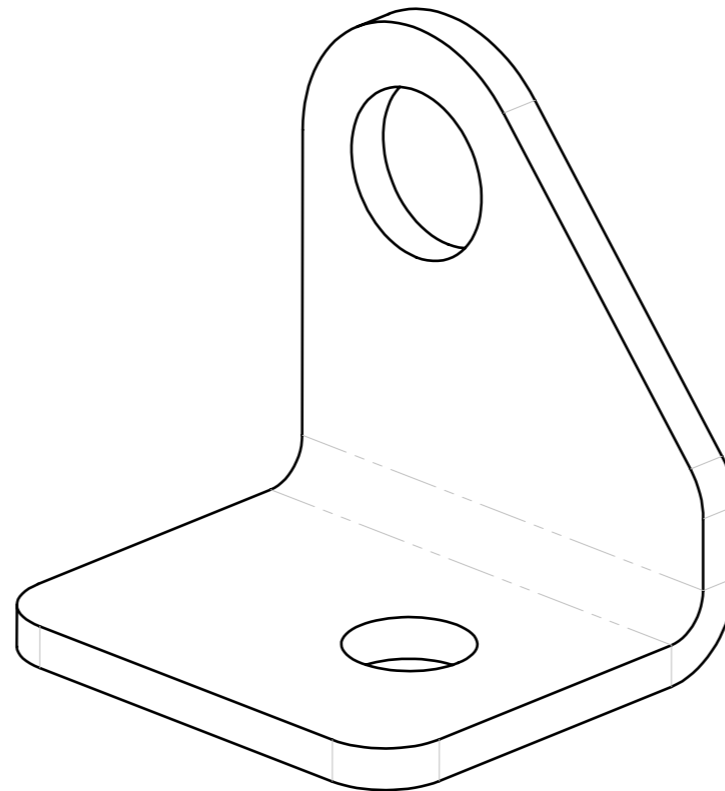
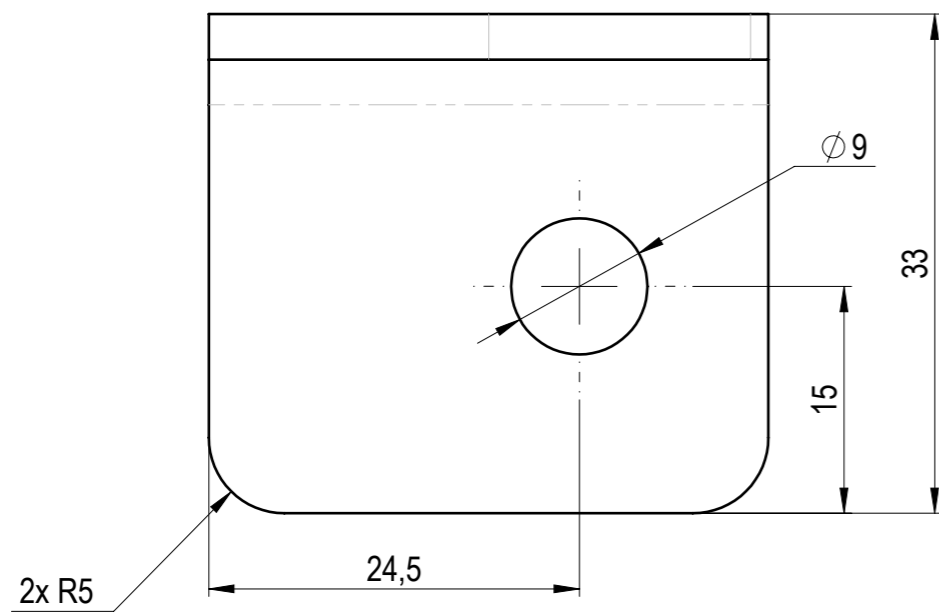
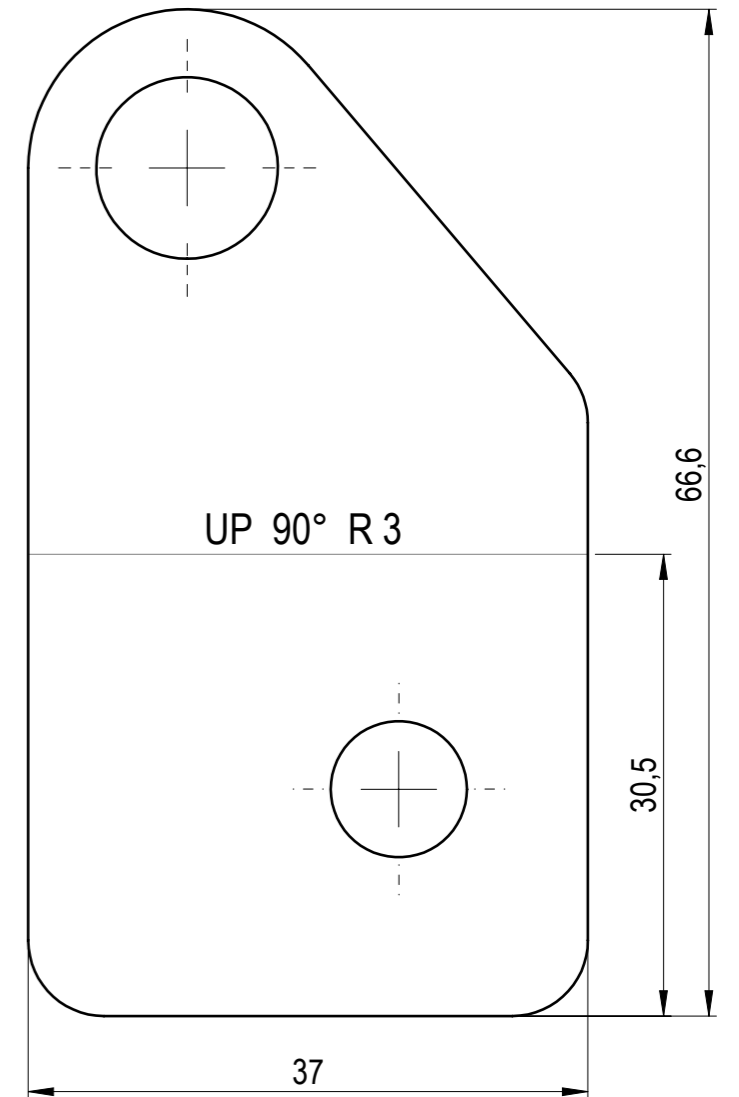

Other dimensions from .DXF file.

SHEET METAL INFORMATION	
Length, mm	66.6
Width, mm	37
Thickness, mm	3
Inside Bend Radius, mm	3
K-Factor	0.5
No. of Bends	1

	MATERIAL	WEIGHT	DEBURR AND BREAK SHARP EDGES DO NOT SCALE DRAWING		REVISION	DATE
	S355	0.046 Kg				09.06.2025
	SURFACE PROTECTION	MACHINING	THERMAL CUTTING	WELDING	SCALE	FORMAT
	HDG EN ISO 1461	ISO 2768 mK	ISO 9013 221	ISO 13920 BF	2:1	A3
	NAME	SIGNATURE	PART NO.			
Designed by	D. Dislers		105-30130-02			
Drawn by	D. Dislers		DESCRIPTION			
Technical ref.			Rod bracket			SHEET 1/1